

## INSTALLATION, OPERATION & PARTS



**▲ WARNING**

This equipment must be installed and serviced by a qualified technician in accordance with all applicable codes and ordinances. Improper installation can create hazards which could result in property damage, serious injury or death. Improper installation will void the warranty. **The NOTICE label indicates special instructions that are important but not related to hazards.**

**Notice to Installer**

This manual contains important information about the installation, operation and safe use of this product. Once installation is complete, this manual must be given to the owner / operator of this equipment.

## CHAPTER 1: IMPORTANT SAFETY INSTRUCTIONS

### READ AND FOLLOW ALL INSTRUCTIONS

1. The Sand Filters are designed to work with water at a temperature from 32°F and 113°F. The filter should never be operated outside of these temperatures or damage may occur.
2. The installation should be carried out in accordance to the safety instructions of swimming pools and the specific instructions for each facility.
3. The user should make sure that the installation is carried out by qualified authorized persons and that these persons have first carefully read the following instructions. Incorrectly installed equipment may fail, causing severe injury or property damage.
4. The operating safety of the filter is only guaranteed if the installation and operation instructions are correctly followed.
5. To reduce the risk of injury, do not permit children to use this product.
6. Incorrectly installed equipment may fail, causing severe injury or property damage.
7. Chemical spills and fumes can weaken Swimming Pool or Spa. Corrosion can cause filters and other equipment to fail, resulting in severe injury or property damage. Do not store pool chemicals near your equipment.
8. Any modification of the filter requires the prior consent from the supplier's original replacement parts and accessories authorized by the manufacturer ensure a high level of safety. The supplier assumes no liability for the damage and injuries caused by unauthorized replacement parts and accessories.

### Sand Filtration System Working Principle

Incoming water from the piping system is automatically directed by the Multi-Port Valve to the top of the filter bed. As the water is pumped through the filter sand, dirt and debris are trapped by the filter bed, and filtered out. The filtered water is returned from the bottom of the filter tank, through the Multi-Port Valve and back through the piping system.

## CHAPTER 2: PREPARATION BEFORE INSTALL

**▲WARNING** This product should be installed and serviced only by a qualified professional.

1. Position the filter next to the Swimming Pool or Spa.
2. The filter should be placed on a level concrete slab, very firm ground, or equivalent. Ensure that the ground will not subside, preventing any strain from the attached plumbing.
3. Position the filter so that the piping connections, Multi-Port Valve and winter drain is convenient and accessible for operation, servicing and winterizing.

4. Ensure that the compliance label is facing the front to allow easy identification in the case of service difficulties.

## CHAPTER 3: INSTALLATION INSTRUCTIONS

**▲WARNING** This product should be installed and serviced only by a qualified professional.

1. Put the filter tank on the base. Turn the filter tank to the right to tighten it. Position the outlet drain plug so it is facing outside for easy operation.
2. Before filling the filter media into the filter vessel, do a visual check of the laterals. Look for broken or loose laterals. Replace if necessary. The laterals of side-mount valve sand filter are all installed.
3. Match the Raised Point of the laterals to Folding Umbrella lateral holder, insert the laterals and turn 90° clockwise. Listen for a sound to confirm the lateral is in place. Please refer to following picture.

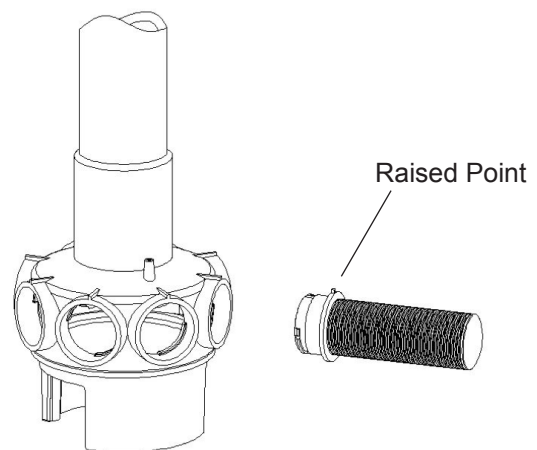

4. Make sure the air release hose is running along side the body of the lateral holder. One end of the air release hose **MUST** be out of the sand. **DO NOT** bury the air release hose in the sand.
5. To eliminate stress on the laterals, fill the filter vessel with enough water to provide a cushioning effect when the filter sand is poured in.
6. Use the clear clamshell cover to protect the filter top mount and make sure the central stem pipe has been fully covered.
7. Carefully pour the exact amount of sand into the filter vessel (see sand filter tank label for amount or chapter 9 of this manual). **DO NOT** allow sand to go into the stem pipe. **DO NOT** damage the filter top mount or it can cause a leak.
8. Put the O-Ring on the the top mount valve and then connect the valve on the filter vessel. The stem pipe should be straight and aligned with the top mount valve. Tighten the flange clamp on the valve. **NOTE:** The flange clamp should be in place and tight or it could cause injuries.

9. To connect the pump to the base, use the screws from the pump hardware pack. Use the pump manual to install the and operate the pump.
10. Adjust the valve position. The white pressure hose connects to the pump output/input valve.
11. The other two connection ends of the valve connect to the swimming pool and the drain outlet hose.

#### Installation Notes

1. Make sure the filter is worked under the work pressure and using a pressure control valve when the system is using a booster pump.
2. If the pump position is higher than the water level, it requires to install the back water control valve.
3. If the pump position is lower than the water level, it requires installing an isolation valve.
4. Minimize the length of pipe and the number of fittings to minimize friction loss to ensure maximum efficiency.
5. Connect all plumbing to the Multiport Valve taking care that all joints are glued or tightened securely to prevent leaking.
6. To prevent breakage and damage to the pump and Multiport Valve, use only pipe sealants specifically formulated for plastics.
7. Ensure solvents are not excessively applied to fittings as this could run into O-Rings and create sealing problems.
8. Do not over tighten fittings or adapters.

#### Installation of the Multiport Valve

Top Mount Sand Filters are supplied with a screw down

Multiport Valve. Supplied with the Multiport Valve are Flange clamp, screws and O-Ring.

1. Screw the barrel unions onto the threaded ports on the Multiport Valve.
2. When rotating the Multiport Valve into position on a Top Mount Filter, leave some leeway for better alignment of plumbing.
3. Once the Multiport Valve is in position and the plumbing is aligned, apply the thread tape to the barrel union thread.
4. Using the roll of Teflon tape wrap the Teflon tape around the thread (tail) of the barrel union in a clock wise direction.
5. Screw the barrel union into the thread of the Multiport Valve and hand tighten. The barrel union should be firmly threaded into the Multiport Valve and there should be no play between the thread.
6. Once you have done this tighten the barrel union with an appropriate tool until it is tight.
7. Repeat steps until all barrel unions are firmly onto the Multiport Valve.
8. Glue the plumbing to the Barrel unions and allow 24 hours for glue (solvent) to set before starting the filter.

9. Test the filter and check for leaks around the threads. If leaking occurs disconnect plumbing and repeat the steps 2 to 6 until the leak has stopped.

#### CHAPTER 4: INITIAL STARTUP OF FILTER

Be sure correct amount of filter media is in tank and that all connections have been made and are secure.

1. Depress Multiport Valve handle and rotate to the BACKWASH position. **NOTE: To prevent damage to control valve seal, always depress handle before turning.**
2. Switch on the Pump. Open the Inlet Valve allowing the filter tank to fill with water. **CAUTION: All suction and discharge valves must be open when starting the pump. Failure to do so could cause severe personal injury and/ or property damage. NOTE: If a pump is installed, switch the pump on and off, instead of closing and opening the Inlet Valve.**
3. Once water flow is steady out the waste line, run the pump for at least one minute. The initial backwashing of the filter is recommended to remove any impurities or fine sand particles in the filter media.
4. Turn the pump off. Set the Multiport Valve to the RINSE position. Switch on the Pump. Open the Inlet Valve until water in sight glass is clear - approximately 10 to 15 seconds.
5. Switch off the Pump. Close the Inlet Valve, set the Multiport Valve to the FILTER position and Switch on the Pump. Open the Inlet. Your filter is now operating in the normal filter mode.
6. Adjust pool suction and return valves to achieve desired flow. Check the plumbing and filter for water leaks and tighten connections, bolts, and nuts, as required. **NOTE: During initial clean-up of the pool water, it may be necessary to backwash frequently due to the unusually heavy initial dirt load in the water.**
7. Record the pressure gauge reading (start up pressure) during initial operation. After a period of time, the accumulated dirt and debris in the filter causes a resistance to flow, and the flow diminishes. The pressure will start to rise and the flow of water will start diminishing. When the pressure gauge reading is 8-10 PSI higher than the initial "Start up" pressure, it is time to backwash (clean) the filter (see Backwashing). **NOTE: To prevent unnecessary strain on piping system and valving, always shut off the pump before switching filter control valve position. To prevent damage to the pump and filter and for proper operation of they system, clean pump strainer and skimmer baskets regularly.**

## CHAPTER 5: MULTIPORT VALVE OPERATION

## CHAPTER 6: BACKWASHING

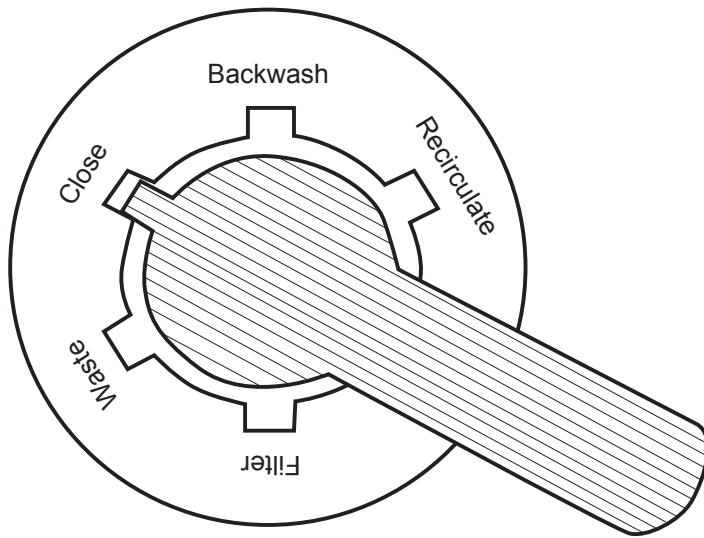

1. **Filter:** Position for filtering the body of water. Incoming water from the piping system is automatically directed by the Multiport Valve to the top of the filter bed. As the water is pumped through the filter sand, dirt and debris are trapped by the filter bed, and filtered out. The filtered water is returned from the bottom of the filter tank, through the Multiport Valve and back through the piping system.
2. **Backwash:** Position for cleaning the filter media. Water flow is reversed by the Multiport Valve through the filter bed so that water flow is directed to the bottom of the tank and up through the filter bed, flushing the previously trapped dirt and debris out the waste line.
3. **Rinse:** Position for flushing the filter system. The water flow is directed by the Multiport Valve through the filter bed and out the waste line. This process settles the filter media bed into place and ensures any dirt or debris is rinsed out of the filter, preventing possible return to the Swimming Pool or Spa.
4. **Waste:** Position for bypassing the filter bed to Waste. The water flow is directed by the Multiport Valve straight to the backwash outlet, bypassing the entire filter bed. This Multiport Valve position is used to lower the water level or for vacuuming water with high dirt loads. **NOTE:** *This position is not available on 4-Way Multiport Valves.*
5. **Re-circulate:** Position for bypassing the filter bed to the Swimming Pool or Spa. The Multiport Valve recirculates water flow directly back to the Pool or Spa, bypassing the filter. **NOTE:** *This position is not available on 4-Way Multiport Valves.*
6. **Closed:** Position for closing all flow to the filter. This position is not to be used with the pump operating. **NOTE:** *This position is not available on 4-Way Multiport Valves. CAUTION: Operation of the Multiport Valve or mode selection is to be always done with the pump switched off.*

The function of backwashing is to separate the deposited particles from filter media grains and flush them from the filter bed. Backwashing is achieved by reversing the flow of water through the filter bed at a fairly high flow rate. This high flow rate expands the filter bed and the water collects the debris taking it to waste.

### Conditions for Backwashing

Time for backwashing is determined by the following conditions:

1. The flow rate through the filter bed decreases until it is insufficient to meet the demand.
2. The removal efficiency of the filter bed decreases to the point where the effluent quality deteriorates and is no longer acceptable.
3. When the pressure gauge reading is 7.2 PSI higher than the start up pressure.
4. If the filter is connected to mains water, pressure rise is not an accurate indicator as mains pressure tends to fluctuate. It is best to rely on the actual flow rate. **NOTE: We recommend that you backwash a swimming pool sand filter in a residential installation at least once a month.**

### Importance of Backwashing

The importance of backwashing cannot be overstated. Dense filter media can become “packed” without proper and frequent enough backwashing. Debris will remain trapped and create channeling within the filter bed. This will result in the filter bed exhausting early. Moreover, if debris is not flushed from the media grains, the filter bed will become dirtier and dirtier as time goes on until the filter operation fails.

### Backwashing Instructions

1. Switch off the Pump. Close the Inlet Valve. **NOTE:** If a pump is installed, switch the pump on and off, instead of closing and opening the Inlet Valve.
2. Release the filter’s pressure by loosening Pressure Release Valve until the Pressure Gauge needle drops to zero <0>.
3. Retighten Pressure Release Valve.
4. Depress and turn Handle 180° to the BACKWASH position. In the BACKWASH position, the water flow is automatically reversed through the filter so that it is directed to the bottom of the filter vessel, up through the sand, flushing the previously trapped dirt and debris out the waste line.
5. Switch on the Pump. Open the Inlet Valve. Backwash water will flow out through drain pipe.
6. When the backwash water in the sight glass appears clear, Switch off the Pump. Close the Inlet Valve.

7. Depress and turn the handle to the RINSE position. In the RINSE water flow is directed through the filter bed and out of the filter through the backwash outlet. This process settles the filter media bed into place and ensures any dirt or debris is rinsed out of the filter, preventing possible return to the pool.
8. Switch on the Pump. Open the Inlet Valve. Rinse water will flow out through the drain pipe.
9. When the rinse water in the sight glass appears clear. Switch off the Pump. Close the Inlet Valve.
10. Depress and turn the handle to the Filter position and Switch on the Pump. Open the Inlet Valve for normal operation.

## CHAPTER 7: MAINTENANCE

The filter media will only require replacement once it has reached the limits of its designated life. Refer to the product information of the particular filter media used. To ensure the maximum life of the selected filter media, please follow the procedures below.

1. Backwash the filter regularly according to the instructions set under BACKWASHING.
2. Maintain a correct chemical balance for your pool or spa's water. The chemical balance of the water is a relationship between its pH, Total Alkalinity, Calcium Hardness and water temperature. The water must be maintained to the following:
  - pH Level: 7.2-7.8.
  - Total Alkalinity: 80-175ppm
  - Calcium Hardness: 175-300ppm

## CHAPTER 8: TROUBLESHOOTING

**Above normal or excessive force to operate the Multiport Valve:** Scoring or jamming with foreign matter or debris. If this condition persists after rinsing, disassemble the valve to clear. Continued operation of the valve may result in a non-sealing condition (damage to spider gasket). This will lead to water loss to the backwash line or to inefficient filtration.

### Dirty Water:

1. Insufficient filtration time.
2. Heavy contaminants or dirt load.
3. Dirty filter, requires backwashing.
4. Air leaking on suction (influent line).
5. Pump impeller vanes blocked.
6. Insufficient water supply (water level low, blockage).
7. Pump not primed.
8. Incorrect water chemistry.
9. Excessive flow of water for filter size. Foreign matter or debris forced through filter bed and through the underdrain.

### Filter Media in the backwash:

1. Excessive quantity of media in the filter.
2. Excessive water flow.
3. Incorrect size or grade of filter media.

### Filter Media returning to Swimming Pool or Spa:

1. Filter is on recirculate.
2. Verify it is the filter media and not from another source.
3. Damage to the underdrain laterals.
4. Damage or incorrect fit of Multiport Valve are correct.
5. Incorrect or mixed grades of media in the filter.

### Short filtration cycles:

1. Presence of algae or scale builds up.
2. Check water chemistry.
3. Excessive water flow, check pump size, mains water flow.
4. Filter blockage. Clean filter media.

## CHAPTER 9: SPECIFICATIONS

ITEM NO.	FLOW RATE GPM	MAXIMUM PRESSURE PSI	FILTER AREA FT	MEDIA REQUIRED LBS
156593	40	50	1.25	100
156594	49	50	2.00	175
156595	50	50	2.80	300

## Above Ground and Inground Sand Filter Systems Item #'s 156593, 156594 & 156595

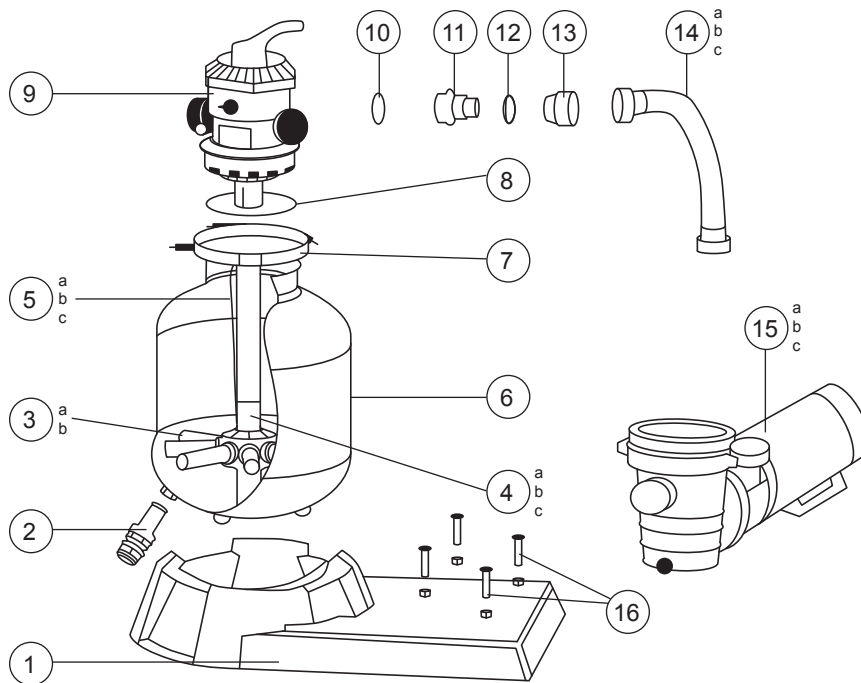

REF No.	PART NUMBER	DESCRIPTION	No. REQ'D
1	647202701080	Sand Filter Support for 156593, 156594 & 156595	1
2	647304073	Drain Plug	1
3a	647304017	Lateral for 156593 & 156594	8
3b	647306016	Lateral for 156595	8
4a	647304079	Center Pipe for 156593	1
4b	647305071	Center Pipe for 156594	1
4c	647306072	Center Pipe for 156595	1
5a	647304172	Air Release Assembly for 156593	1
5b	647305173	Air Release Assembly for 156594	1
5c	647306173	Air Release Assembly for 156595	1
6a	647304008	Filter Tank for 156593	1
6b	647305008	Filter Tank for 156594	1
6c	647306008	Filter Tank for 156595	1
7	647304072	Flange Clamp	1
8	65431012080	O-Ring	1
9	647304071	6-Way Valve	1
10	65431021080	O-Ring	3
11	647303014	Hose Adapter	3
12	65021005000	Hose Clamp	2
13	647201802001	Adaptor	1
14a	647202772	PVC Hose for 156593	1
14b	647202871	PVC Hose for 156594	1
14c	647202971	PVC Hose for 156595	1
15a	2601	3/4 HP HPP Pump for 156593	1
15b	6578	1 HP HPP Pump for 156594	1
15c	6579	1.5 HP HPP Pump for 156595	1
16	65862026000	Screw M8X35 and Nut M8	4